

Vertical In-line Centrifugal Pump

The DESMI NSL pump meets the special marine and industrial market requirements for:

- High efficiency
- Low NPSH values
- Easy installation/service
- Specific materials

and further, an attractive price.



| | |
|-----------------------|--|
| Nominal diameter (DN) | 65 to 400 |
| Flow rate | Up to 1800 m ³ /h (7900 US gpm) |
| Head | Up to 220 m (720 ft) |
| Pressure | Up to 25 bar (363 psi) |
| Temperature | Up to 150°C (302°F) |
| Motor | Standard and EX motors |
| VFD | Direct or Bulkhead/Wall-mounted |
| ATEX approved. | |

| Material specification | A | D |
|------------------------|-------------|-------------|
| Pump casing | Cast iron | Bronze |
| Impeller | NiAl-bronze | NiAl-bronze |
| Wear ring | NiAl-bronze | NiAl-bronze |
| Shaft seal cover | Cast iron | Bronze |
| Shaft | Stainless | Stainless |
| Shaft seal | Mechanical | Mechanical |

Design Features

The pump is a vertical in-line, radially split, single-stage centrifugal pump with connecting flanges according to international standards. The pump is designed to be coupled with electric motors having different international flange dimensions.

The pump casing is equipped with a replaceable sealing ring.

The impeller is made with double-curved blades to ensure low NPSH-values and high efficiency.

The bearing unit is equipped with sturdy ball bearings and the small types are fitted with lifetime-lubricated bearings. In the larger types the lower bearing is a double bearing for which a lubrication point is provided.

Shaft in stainless steel with mechanical shaft seal of an approved brand is standard.

Applications

Within marine industry the pumps are suitable as fresh and seawater cooling pumps, bilge and ballast pumps, fire-fighting and general service pumps, and further for transport of slightly aggressive liquids with low viscosity such as diesel and lubricating oils. Further, the pumps can be supplied in a special version for pumping brine and similar media. Many other applications can be found for these pumps within industry.

All pump sizes are available as self-priming pumps with a separate built-on priming pump of the water ring type, complete with suction strainer and water feed tank.

The priming pump is equipped with its own electric motor and is suitable for manual or automatic start/stop.

The pump can also be equipped with an air-operated ejector priming unit.

Ask for brochures on B114 priming unit or ½"-1" ejector, if you need further information about this - or find it on our website.

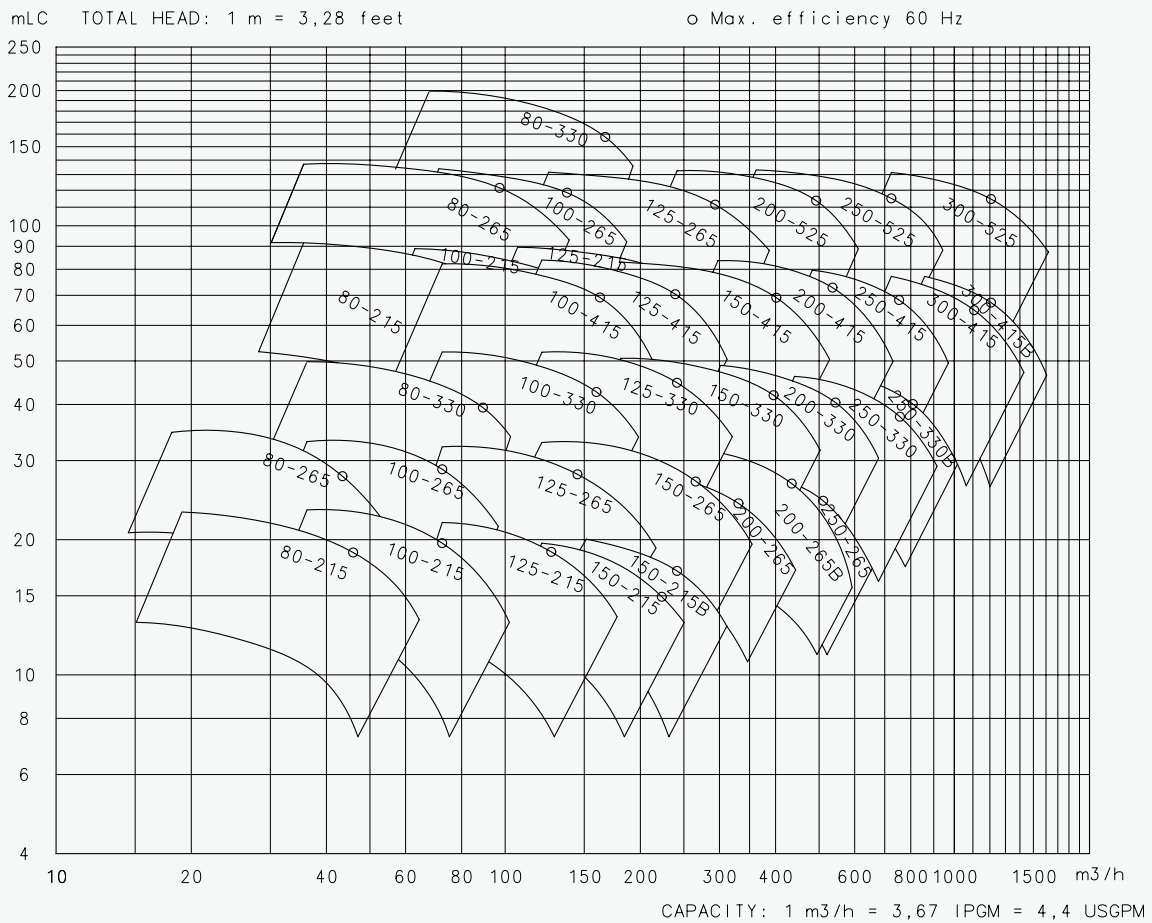

Design Details

Pumps with $\varnothing 215$ and $\varnothing 265$ Impeller
Suction and discharge flange dimensions are identical. The line through inlet and outlet is flush with the centre line of the shaft. The pumps are mounted with one impeller wear ring.

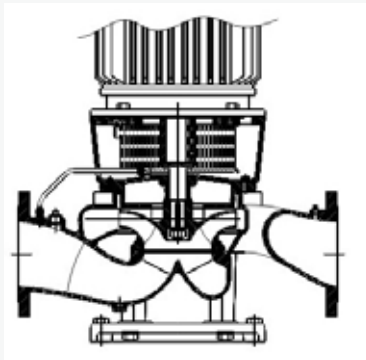

Pumps with $\varnothing 330$, $\varnothing 415$ and $\varnothing 525$ Impeller
Dimension of the suction flange is one size larger than that of the discharge flange. The line through inlet and outlet is tangential offset in relation to the centre line of the shaft. The pumps have two impeller wear rings.

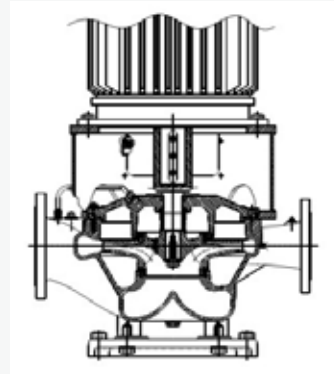

Monobloc without Bearing

The pump is for small capacities and limited space. This version has no pump bearings, only the ball bearings in the standard electric motor. The power transmission is by rigid coupling. Dismantling of the pump parts is possible without removing the pump casing from the piping.

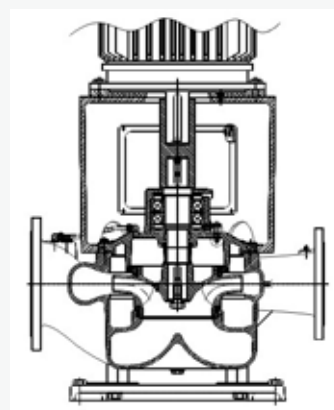
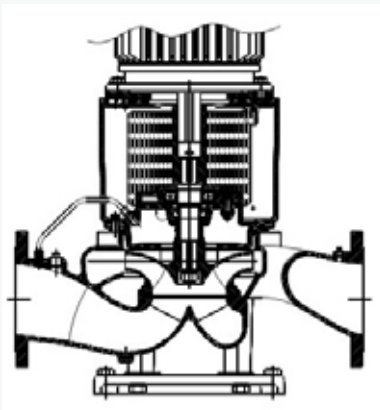

Monobloc with Bearing

The pump is for major capacities and heavy loads, especially recommended where the advantage of the spacer coupling is of no importance and where a small overall height is required.

The pump is equipped with a separate rear cover with a ball bearing and a separate motor bracket. Dismantling of the rotating pump parts is possible without removing the pump casing from the piping.

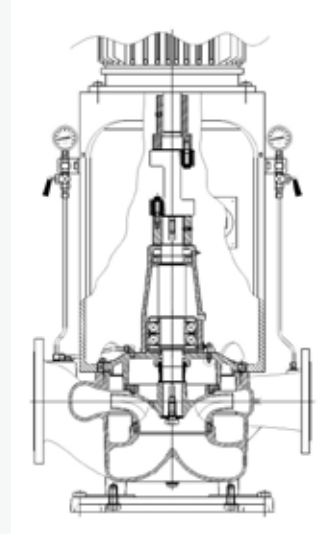
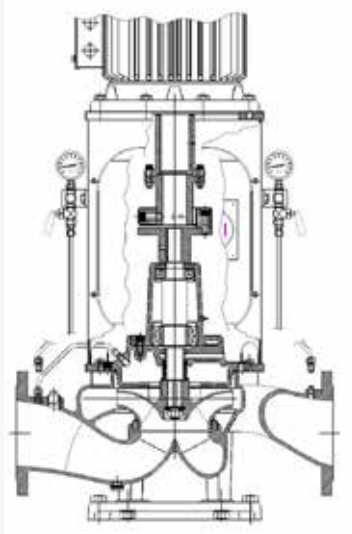

Spacer

The pump is for high capacities, heavy loads, and high pump speeds. As a special feature the pump is equipped with a spacer coupling which is a combined distance and flexible coupling. This makes it possible to remove the complete bearing housing with shaft, bearings, shaft seal, and impeller without dismantling or loosening the motor or piping. For high capacities and the resulting larger and heavier electric motors we recommend this pump version because of the easy dismantling of the rotating pump parts in connection with inspection and repair. This special feature is often a requirement within the marine industry where installations must be easy to service.

NSLV and NSLH

The DESMI NSLV pump is constructed for vertical mount (with suction flange downwards) and the NSLH pump for horizontal mount.

The pumps are particularly suitable for the pumping of water in connection with cooling systems, cooling of diesel engines, as bilge pumps, ballast pumps, fire pumps, brine pumps, pumps for irrigation, fish farms, water works, district heating, salvage corps, army and navy, etc.

The DESMI NSLV and NSLH pumps meet the special marine and industrial market requirements for:

- High efficiency
- Low NPSH values
- Easy installation/service
- Specific materials

and further, an attractive price.



NSLH



NSLV